

Bumble Bee Kill Switch

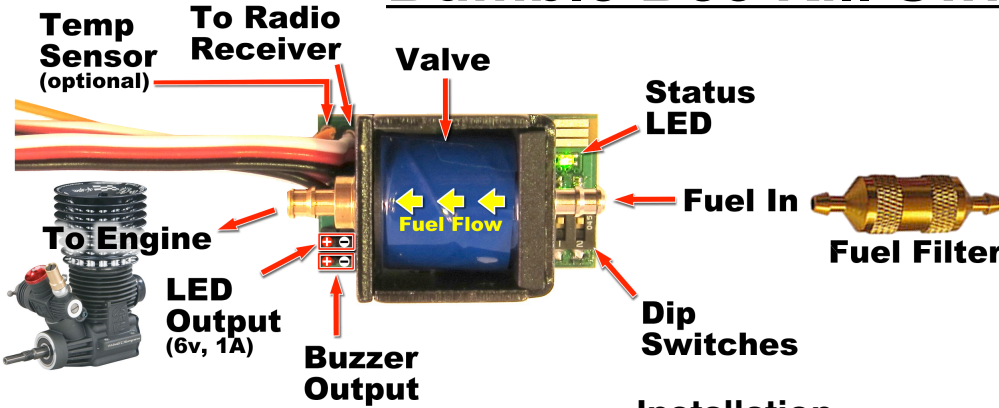

Installation

Trim holes in the clear case for the fuel hoses and wires to pass thru. Find a suitable mounting location and glue or screw down the Bumble Bee securely. Be sure that the supplied 3mm screws do not touch the blue coil when mounted. Cut the fuel hose and put the Bumble Bee inline between the engine and fuel filter (not included). Plug the pigtail cable into an Aux channel on your receiver, or if you don't have an unused channel: plug it into the steering channel and plug your steering servo into the built-in splitter on the Bumble Bee's pigtail.

DIP SWITCH SETUP



Switch 1 up, Switch 2 up
Aux control, Glitch kill
(recommended for radios with an Aux channel)

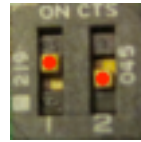

Switch 1 up, Switch 2 down
Aux control, Glitch kill inactive
(use at your own risk)



Switch 1 down, Switch 2 up
Aux inactive, Glitch kill
(recommended for radios with no spare channels)



Switch 1 down, Switch 2 down
Aux inactive, Glitch kill inactive
Fuel flow always open except during power off, low voltage, or high engine temp. (use at your own risk)

STATUS LED

- • Power off - LED off - Fuel flow closed
- ★ • Flashing Amber LED - Voltage cutoff info
- ★ • Flashing Red LED - No radio signal - Fuel flow closed
- • Solid Red LED - Aux channel switched off - Fuel flow closed
- • Solid Green LED - Aux channel switched on - Fuel flow open
- ★ ★ • Flashing Red/Green LED - 5 second wait - Fuel flow closed
- ★ • Flashing Green LED - Safety override - Fuel flow open
- ★ ★ • Flashing Green/Amber LED - Low Voltage - Fuel flow closed
- ★ ★ • Flashing Red/Amber - High engine temp - Fuel flow closed

LOW VOLTAGE CUTOFF

When you turn on the radio receiver power, the LED on the Bumble Bee will flash amber a number of times, letting you know how the low voltage mode is set.

This feature allows you to protect your battery from over-discharge. Once the receiver battery voltage gets down to the set point the fuel valve will close which stops the engine from running and lets you know that it's time to charge the battery.

To change the voltage cutoff point: During the first 5 seconds after turning on the radio receiver power you need to cycle the #1 dip switch up/down or down/up to move to the next set point. 3v to 4v to 5v to 6v and then back to 3v. For example: if you are set at 4v cutoff and you wanted to move up to 6v cutoff you would need to cycle the #1 switch back and forth two times. This setting is remembered.

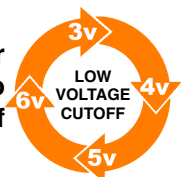

3 Amber flashes = 3v cutoff

4 Amber flashes = 4v cutoff (default)

5 Amber flashes = 5v cutoff

6 Amber flashes = 6v cutoff

For more info visit: www.KillerRC.com Email: info@KillerRC.com